

BOX INSONORIZZANTE - SOUNDPROOF BOX - BOÎTE POUR LA RÉDUCTION - SCHAULDÄMMBOX FÜR VENTILATOR - BOX INSONORIZANTE



STANDARD ITALIANO

- BOX-INS-AL100/150
- BOX-INS-AL200/300
- BOX-INS-AL400
- BOX-INS-AL550
- BOX-INS-AL750
- BOX-INS-AL1000

EUROPEAN STANDARD

- BOX-INS-AL100/150-D
- BOX-INS-AL200/300-D
- BOX-INS-AL400-D
- BOX-INS-AL550-D
- BOX-INS-AL750-D
- BOX-INS-AL1000-D



Box insonorizzante per attimento rumorosità degli aspiratori.



Soundproof box to reduce the fans noise.



Boîte pour la réduction du bruit acoustique des.



Schauldämmbox für Ventilator. Komplett mit Ansaug- und Ausblasöffnung für Innenund Aussenpositionierung.



Box insonorizante para la reducción del ruido del electroaspirador.

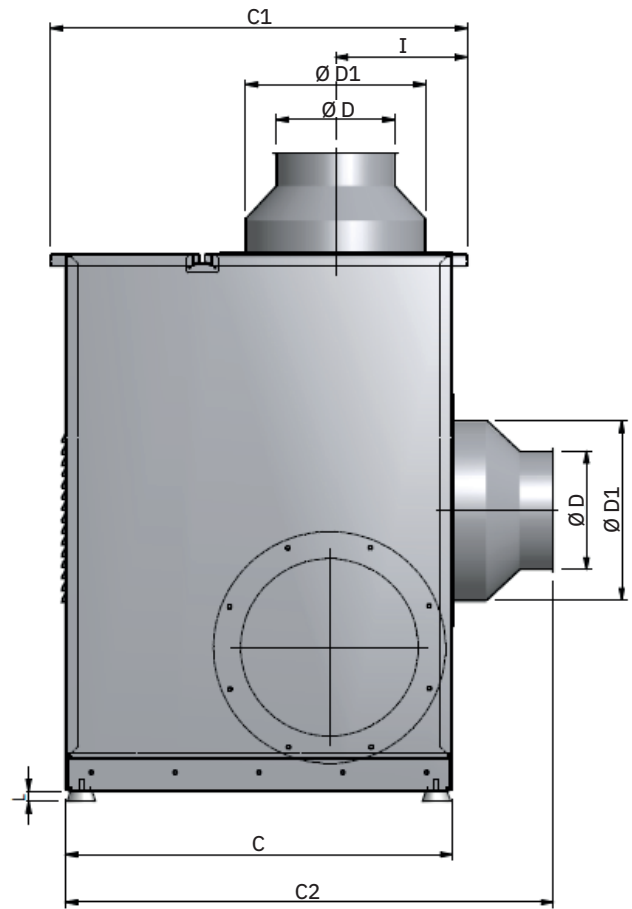
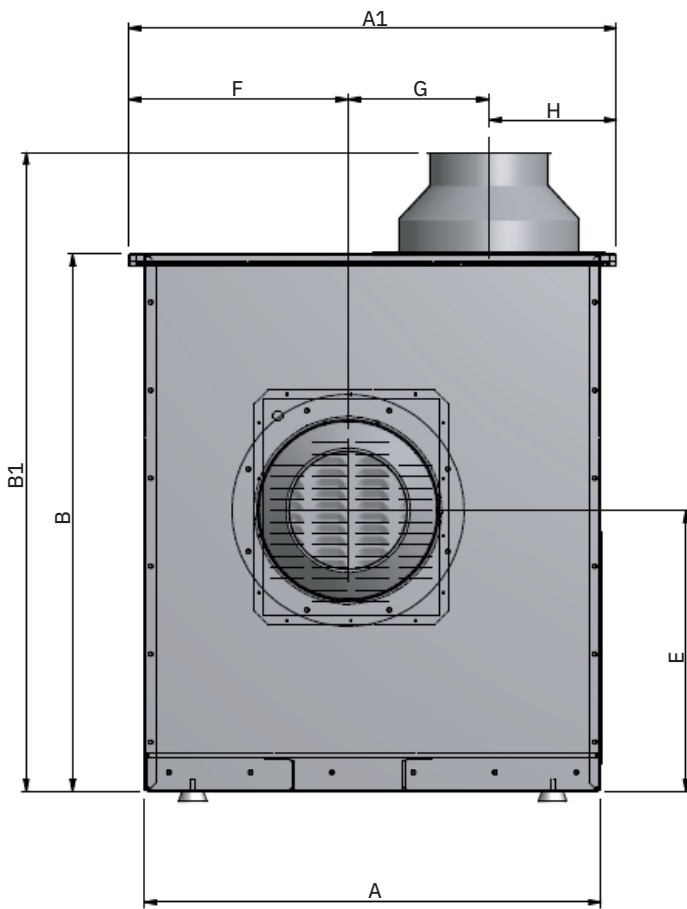

BOX INS																
CODE	A	A1	B	B1	C	C1	C2	Ø D1	Ø D	E	F	G	H	I	L	Weight
BOX-INS-AL100/150	610	670	740	955	552	612	767	240	180	380	280	152	238	228	25	65
BOX-INS-AL200/300	710	770	913	1128	648	708	863	260	200	472	300	203	267	267	25	89/91
BOX-INS-AL400	960	1030	1135	1350	818	888	1033	380	250	594	463	298	269	269	25	185
BOX-INS-AL550	960	1030	1135	1350	818	888	1033	380	250	594	463	298	269	269	25	189
BOX-INS-AL750	1070	1140	1121	1221	838	900	1053	450	300	651	472	354	310	310	25	-
BOX-INS-AL1000	1070	1140	1121	1221	838	900	1143	450	300	651	472	354	310	310	25	-



Stesse misure sia per lo standard italiano che per quello europeo



Same measures for both Italian and European standards.



Mesures identiques pour les normes italiennes et européennes.



Gleiche Maßnahmen für italienische und europäische Normen.







Las mismas medidas para las normas italianas y europeas.

MENSOLA A PARETE - WALL BRACKET - SUPPORT MURALE - WANDHALTERUNG FÜR VENTILATOR - ENCIMERA A PARED





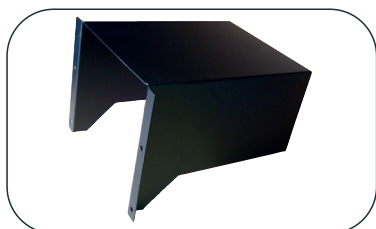

ME-50-300/P
ME-400-
1000/P

-  Mensola a parete per sostegno aspiratore. ME-50-300/P è compreso di piedini.
-  Wall bracket to stand the fan. ME-50-300 / P is comprised of pins.
-  Support mural pour soutenir l'aspirateur. ME-50-300 / P est constitué de broches.
-  Wandhalterung für Ventilator. ME-50-300 / P wird von Stiften besteht.
-  Encimera a pared para el montaje de los aspiradores. ME-50-300 / P se compone de pasadores.

COPRI MOTORE - COVER FOR ELECTRIC MOTOR - COUVERCLE POUR MOTEUR - MOTORDECKEL - CUBREMOTOR







CM-0.5-0.75
CM-1-1.5
CM-2-3
CM-4-5.5
CM-7.5-10
CM-15-20
CM-0.75/AS
CM-1-2/AS

-  Copertura per motore elettrico degli aspiratore.
-  Cover for electric motor of the fan.
-  Couvercle pour moteur électrique de l'aspirateur.
-  Motordeckel.
-  Cubremotor para aspiradores.

PIEDINI ANTI VIBRANTI - ANTI-VIBRATION FEET - PIEDS ANTI-VIBRATION - SCHWINGUNGSDÄMPFER - GOMAS ANTIVIBRACIONES







SET-PIEDINI/P
SET-PIEDINI/M
SET-PIEDINI/G

-  Piedini antivibranti per collegamento aspiratore con relativo supporto.
-  Anti-vibration feet for connection with suction stand.
-  Pieds anti-vibration pour la connexion avec le support d'aspiration.
-  Schwingungsdämpfer.
-  Gomas antivibraciones para enlace del aspirador con el relativo soporte.

GIUNTO ANTI VIBRANTI - VIBRATION-PROOF - JOINT ANTI-VIBRATIONS - FLEXIBLE VERBINDUNG - JUNTA ANTIVIBRACIONES





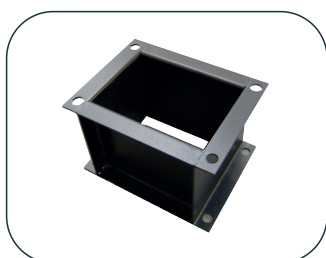

GNT-150 GNTS-160
GNT-160 GNTS-200
GNT-180 GNTS-315
GNT-200 GNTS-355
GNT-250 GNTS-400
GNT-300
GNT-315
GNT-350
GNT-355
GNT-400

-  Giunto antibrante con risvolti per collari.
-  Vibration-proof coupling with lip for collars.
-  Joint anti-vibrations pour collier.
-  Flexible Verbindung mit Rand.
-  Junta antivibraciones con solapa para collares.

CAVALLETTO A PAVIMENTO - STAND FOR EXHAUSTER - SUPPORT POUR SOUTENIR - VENTILATORGESTELL - CABALLETE PARA SOPORTE



CV-50-300/P
CV-400-550/P
CV-750-1000/P
CV-1500-2000/P

-  Cavalletto per supporto aspiratore.
-  Stand for exhaustor fan.
-  Support pour soutenir l'aspirateur.
-  Ventilatorgestell.
-  Caballete para soporte del aspirador.